

Two-Piece Secondary Containment Pipe & Fittings Installation Data

IMPORTANT • READ THIS FIRST

Before beginning actual assembly procedures, read to assure all individuals involved in the installation thoroughly understand the following suggestions and precautions:

You must use Manual No. F6000 or F6080 with these instructions.

In all cases, the bonding surfaces must be clean and dry before applying adhesive. All bonding surfaces must be factory fresh in

appearance. When machined ends have been stored in direct sunlight, surfaces will weather and result in loss of bond strength. When surfaces are weathered, sand or re-scarf spigots and sand sockets to achieve a factory fresh appearance.

Use of approved field scarfing tools is recommended to obtain a uniform scarf dimension and a snug fit. During set up of the scarfing tools, dry fit

to make sure the two halves of the fittings close together completely on both sides (see Fig. 6).

Do not move secondary containment joints prior to adhesive cure.

The instructions for assembling the primary piping are shown in Manual No. F6000 which must be used with these instructions for containment systems.

Introduction

These instructions cover only the assembly of the secondary system. Manual No. F6000 must be used for primary installation instructions. Procedures common to both systems, such as cutting, handling, adhesive mixing, etc., are presented in Manual No. F6000 and F6080.

These installation instructions are for low pressure (drain) secondary containment systems. All references to secondary containment systems in these instructions are related only to low pressure, gravity drain systems. The secondary containment system is designed for use with **RED THREAD® II, GREEN THREAD®, CENTRICAST® CL, RB, and Z-Core** primary pipe.

The secondary containment piping system consists of the next larger pipe size (as a minimum) and special two-piece fittings. Fitting manufacturing process is by either the compression molding process, or the contact molding process. Contact molding includes spray-up and/or hand lay-up process.

The washer head bolts and threaded inserts required for assembling the fittings are supplied, with the inserts mounted in the fittings. One exception: Laterals are supplied with nuts, bolts, and washers because the parts are not mirror-image. Three types of adhesive are available for assembly. The 8000 series adhesives require filler kits containing pre-weighed amounts of filler to

increase the viscosity of the mixed adhesive when used with two-piece fittings. **Note:** When standard primary sleeve coupling is used in the containment piping, do not use filler. These piping systems are recommended for corrosion services over a broad pH range. Consider the chemical recommendations for RED THREAD II (epoxy pipe) for a conservative evaluation. Refer to Bulletin No. E5615 for chemical resistance/operating temperature recommendations. Contact NOV Fiber Glass Systems when necessary for a more detailed recommendation.



www.fgspipe.com

2700 West 65th Street
Little Rock, Arkansas 72209
Phone: 1 (501) 618-2256

25 S. Main Street
Sand Springs, Oklahoma 74063
1 (918) 245-6651

NOV Fiber Glass Systems

SECTION 1 Secondary Containment Piping Components

A. Containment Piping—Secondary containment piping sizes are as follows:

Primary Pipe Size (In.)	Minimum Containment Pipe RTII, GT (In.)	Minimum Containment Pipe RB, CL, ZC (In.)
1	-	3
1½	-	3
2	3*	3*
3	4*	4*
4	6*	6*
6	8	8
8	10	10**
10	12	12
12	14	14
14	16	16

RT II = RED THREAD II
GT = GREEN THREAD
ZC = Z-CORE

CL = CENTRICAST CL
RB = CENTRICAST RB

B. Containment Fittings – Secondary containment fittings and components are as follows:

Note: Some standard primary fittings such as saddles, tapered sleeve couplings, etc., may be used with containment piping systems.

Component	Use
45° elbow	Contain primary 45° elbow
90° elbow	Contain primary 90° elbow
Tee	Contain primary tee
Coupling	Contain primary coupling
Lateral	Contain primary lateral
Concentric reducer	Contain primary concentric reducer
Termination fitting	Terminate containment on primary pipe
Anchor assembly	Anchor primary to containment pipe
Centralizer	Support primary pipe in containment

Table 1 - Number of Bolt⁽¹⁾ Holes in Containment Fittings

Size (In.)	45° Elbow	90° Elbow	Tee	Lateral	Conc. Red.	Cplg.
3	9	10	11	13	-	10
4	9	10	11	13	6	10
6	9	10	11	14	8	10
8	15	17	19	16	10	14
10	19	21	27	32	8	12
12	25	29	38	42	10	12
14	26	30	39	50	18	14
16	26	31	39	54	18	14

Refer to Tables 1 and 2 for bolt hole and dimensional data.

C. Adhesive for Secondary Containment Piping—

For RT and GT secondary systems, use 8000 series adhesive with filler. Because of the quantity of adhesive required for secondary containment fittings, fillers are supplied for the standard (8014) and larger (8069) size adhesive kits only. For CL, RB and ZC secondary systems, use ZC275 adhesive. Filler not required for this adhesive.

* When using 2", 3", or 4" sweep fittings, use containment pipe and fittings that are two diameter sizes larger than the primary.

(1) Bolt sizes: 3"- 6" Secondary Containment = ¼ - 20 x ¾"
8"-16" Secondary Containment = 5/16 - 18 x 1¼"

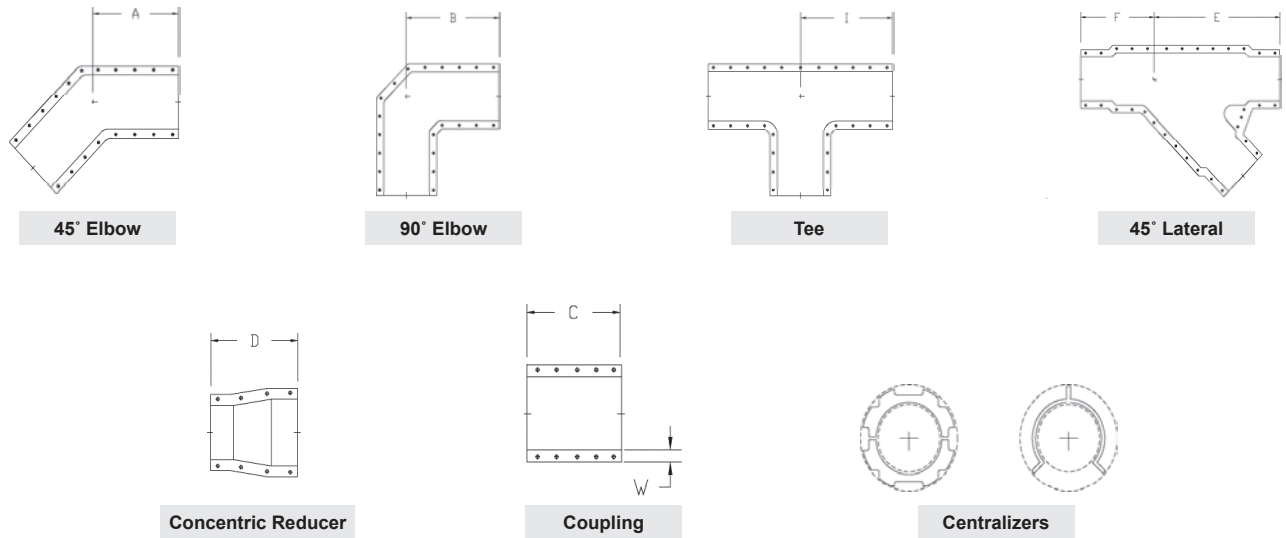

Figure 1

For RT/GT, contact NOV Fiber Glass Systems for recommendations on anchors and terminations.

Table 2 - Dimensional Data for Containment Fittings

Containment Size (In.)	A	B	C	D	E	F	G	W
3	6	7	14	—	11	7	8¼	1½
4	7½	8	14	6	13	7	8¾	1½
6	8	9	16	11	15	8	9¾	1½

Containment Size (mm)	A	B	C	D	E	F	G	W
80	152	178	356	—	279	178	210	38
100	191	203	356	152	330	178	219	38
150	203	229	406	279	381	203	238	38

SECTION 2 System Layout

A. Primary Piping—Assemble primary piping according to the installation instructions in Manual No. F6000 or F6080.

B. Containment Piping—In some cases, the procedures for tapered joints from Manual No. F6000 are required for assembling secondary containment joints. Pipe ends joined to containment fittings must be scarfed, while pipe ends joined to tapered couplings must be tapered spigots.

Containment pipe is placed over the primary pipe during assembly of the primary joints. As the primary pipe is assembled, centralizers are bonded to or snapped on the primary pipe depending on size. Smith Fiberglass supplies two types of centralizers (see Fig. 1). Thermoplastic snap-on centralizers are used for smaller sizes—up to 6" primary. Bond-on centralizers are used on larger sizes. Use $\frac{1}{16}$ " thick double-sided foam tape inside the thermoplastic centralizers to hold them in place. Sand the primary pipe O.D. before attaching bond-on centralizers.

Note: Thermoplastic centralizers will be much stiffer in cold weather. Treat similar to adhesive; prewarm in cold weather before attempting installation.

Careful planning of the pipe layout will allow inspection of the primary joints by moving the secondary containment pipe along the primary pipe. During the layout planning, it may be necessary to include a two-piece secondary containment coupling in the layout to allow additional clearance for inspecting the primary joints. It is a good practice to obtain a few extra two-piece couplings for the containment system in case it is necessary to provide clearance for inspecting the inner pipe.

NOTE: Coupling placement must be planned before positioning of containment pipe, because the pipe must have scarfed ends. Additional consideration may be necessary for various types of leak detection systems.

C. Calculating Lengths for Containment Piping—To determine the length of the containment piping, you must first dry fit the primary joints. Make sure that the tapered primary joints are fit tightly together, and place the bottom half of the containment fittings under the primary fittings.

Use a tape measure to determine the distance from the edge of the two containment halves placed under the primary fittings. Check Table 3 to determine the insertion depth of the containment pipe (minimum bond length).

Refer to Section 10 on Close Tolerance Piping in Manual No. F6000 to determine the “make up” dimension for the primary piping. The adhesive acts as a lubricant during insertion of the spigot when bonding the primary system. This results in additional insertion length (“make up”) when bonding the joints. Make allowances for the “make up” length when calculating the length of the containment pipe. The calculation procedure is as follows:

Table 3 Minimum Bond Lengths for Secondary Containment Fittings

Containment Size (In.)	Minimum Bond Length (L _B) (In.)
3	2 $\frac{3}{4}$
4	2 $\frac{3}{4}$
6	2 $\frac{3}{4}$
8	3
10	4
12	4 $\frac{1}{2}$
14	4 $\frac{1}{2}$
16	4 $\frac{1}{2}$

- Determine the distance from the edges of the containment fittings.
- Add the minimum bond lengths for both containment joints (shown in Table 3). This will provide pipe for insertion into the sockets of the containment fittings.
- Subtract the “make up” dimensions for the primary joints (from Section 10 of Manual No. F6000). This will allow for the decrease in overall length of the primary piping when assembled.

In equation form:

$$RT/GT: L_p = X + 2L_B - 2M$$

$$CL/RB/ZC: L_p = X + 2L_B$$

Where:

$$L_p = \text{Containment pipe length, ft.}$$

- X = Distance from edge of one containment fitting to the edge of the next containment fitting
- L_B = Minimum bond length for containment joints
- M = Make up dimension for primary joints from Manual No. F6000

Sample problem:

Given: 16" containment pipe over 14" primary pipe.
When laid out, the distance from the edges of the containment fittings is 12' 3".

Solution:

- X = 12' 3"
- L_B = 4 $\frac{1}{2}$ " (minimum for 16" containment joint)
- M = $\frac{3}{4}$ " (14" pipe, Manual No. F6000, Section 10)
- L_P = 12' 3" + 2(4 $\frac{1}{2}$ ") - 2($\frac{3}{4}$ ")
- L_P = 12' 3" + 9" - 1 $\frac{1}{2}$ "
- L_P = 13' - 1 $\frac{1}{2}$ " = 12' 10 $\frac{1}{2}$ "

SECTION 3 - Pipe Preparation

A. Scarfing

Pipe scarfing—Bonding surfaces of containment fittings are sanded in the factory. The containment pipe must be scarfed before assembling with containment fittings that have a socket joint. The scarfed (machined) surface of the pipe must be uniform and free of resin-rich areas. **Note:** For containment pipe connections to tapered fittings, such as tapered sleeve couplings (bell x bell), refer to Manual No. F6000 and corresponding tapering tool instructions.

- b. **Scarfing Tools**—For RT/GT, tools normally used to taper 3" through 12" RT/GT pipe can be used to scarf 3" through 12" containment pipe with the addition of a scarfing adapter kit. **Scarfing kits and instructions must be specified when ordering the containment system components.** The scarfing adapter kits contain special zero degree (0°) blade holders, special cutting (scarfing) blades, and set-up gauges for the 2"-6" tool. The 8"-12" tools will have a special blade holder, diameter tape, and instructions. The 8"-16" taper/scarf tool does not require a scarf kit.

Containment pipe in 8" through 16" sizes can be scarfed with the 8"-16" tapering tool by pulling the taper angle pin and resetting **to zero degrees.**

Table 4 Secondary Containment Pipe Scarfing Dimensions

Cont. Size (In.)	Scarf Diameter (In.)	Min. Scarf Length (In.)	Scarf Circumference* (In.)
3	3.480 ± .010"	3	—
4	4.480 ± .010"	3	—
6	6.615 ± .010"	3	—
8	8.570 ± .020"	4	26 $\frac{5}{16}$
10	10.570 ± .020"	5	33 $\frac{3}{16}$
12	12.550 ± .020"	5	39 $\frac{7}{16}$
14	14.410 ± .020"	5	45 $\frac{1}{4}$
16	16.410 ± .020"	5	51 $\frac{9}{16}$

Field gauges can be made from a short section of pipe (or other type of spacer) to set the depth of cut as long as the scarf dimensions match the scarf diameter and minimum scarf length shown in Table 4.

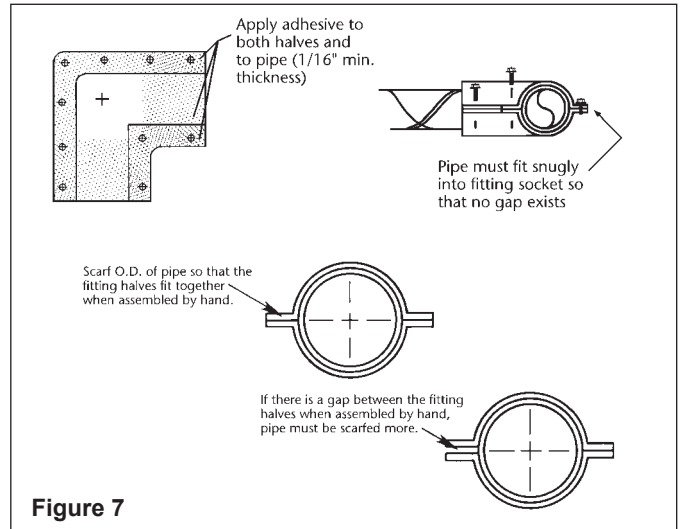

Figure 7

Note: Check the set up of the scarfing tools with a two-piece fitting on a regular basis. The containment fitting must be free to close around the pipe, and the flange (flat) areas of the containment fitting must fit together tightly on both sides (see Fig. 7).

SECTION 4 - Assembly

A. Bonding

- a. **Adhesive requirements**—All bonding surfaces must be clean and dry before applying adhesive. If the surfaces have been contaminated with oil, grease, etc., they must be cleaned as described in the instructions for primary joints (Manual No. F6000 and F6080).

The two-piece fittings require a greater amount of adhesive than the primary (tapered bell and spigot) joints. Adhesive mixing procedures for containment joints are the same as those for primary joints, except that a filler must be added to 8000 adhesive. The adhesive and hardener must be completely mixed before adding the entire contents of the filler kit. Filler kits are available in pre-packaged quantities that correspond to the standard and large adhesive kit sizes. For example, a DS-8014 filler kit is required for a DS-8014 adhesive kit, and a DS-8069 filler kit is required for a DS-8069 adhesive kit. The filler kits must be ordered as separate items in quantities matching the number of adhesive kits required for containment joints. Quantity of adhesive kits required is as shown in Table 5. ZC275 does not require a filler kit.

- b. **Assembly**—The thickened (filled) adhesive may be applied with either the brush or stir stick provided in the adhesive kit. Use a small amount and apply pressure to “wet out” the machined surfaces, then apply a minimum $\frac{1}{16}$ " thick layer of mixed adhesive to all machined surfaces (including the flange areas of the fitting, the socket areas of the fitting, and the scarfed areas of the spigot).

Using the bolting materials, assemble the two-piece fittings over the primary system. The bolts can be tightened with a box wrench or impact wrench. Three-inch through 6" sizes require a $\frac{3}{8}$ " socket; 8" and larger sizes require a $\frac{1}{2}$ " socket. Alternate from side to side and end to end while tightening. Do not tighten from one end or one side in a manner that could cock the fitting to one side. **Note:** If the pipe has not been scarfed to the proper dimension, the two halves of the containment fitting will not properly seal, resulting in a weak joint.

Make sure the scarfed pipe ends are inserted into the sockets of the fittings for a length equal to the minimum bond length shown in Table 3. Note: Be careful not to over-insert on the large end of secondary containment concentric reducers.

Do not disturb the assembled joint until the adhesive is completely cured. Cure times and curing procedures for secondary containment joints are the same as procedures for primary joints (refer to the adhesive instructions). **Note:** Electric heating collars will not cover secondary containment fittings completely. However, you can use several heating collars under, around, and above the containment fittings if all bonded areas are covered (see Fig. 8) or

you may wrap the fitting in heavy-duty foil and cure with a hot air gun.

B. **Industrial Heat Gun**

An industrial heat gun and heavy duty aluminum foil may also be used to create a mini oven around the clam shell secondary containment fitting. Wrap foil around the fitting and cinch the ends down. Cut a 10" to 12" section of 2" or 3" pipe and place inside the foil. Place heat gun in the end of the pipe. Do not place heat gun any closer than 12" from the fitting. Cure time is approximately 15 minutes. For a proper cure, maintain the temperature between 250° and 400°F.

SECTION 5 - Termination

A. Termination Procedure

Termination Fitting (Straight) Termination fitting (straight) consists of two pieces: a special coupling with a ring bonded to the O.D. (the “termination coupling”) and a special short containment coupling (see Figs. 1 and 9). The O.D. of the ring is the same as the scarf diameter of the secondary pipe. The primary pipe is bonded with the special termination coupling. After testing, the special short containment coupling is bonded (see Fig. 9). Where required, the secondary containment coupling used in the termination fitting can be supplied with a threaded outlet. Contact your NOV Fiber Glass Systems representative.

SECTION 6 Testing the Containment System

Note: Local codes or other engineering considerations may dictate changes.

Note: Primary pipe should be tested according to the procedures in Manual No. F6000 or F6080. Testing of the primary piping must be completed before the secondary containment is bonded and tested. This is to allow inspection of the primary joints.

- A. NOV Fiber Glass Systems Products recommends **hydro testing the secondary containment piping system with water to 15 psig**. A hydro test is a better test for finding leaks in any part of the containment piping system. Air tests show leakage only where a soap solution is applied. Wear eye protection. If a hydro test is impractical, refer to paragraph B below.

*Using regular tape measure; $\pm 1/16$ ".

Table 5a Quantity of Adhesive Kits Required per Containment Fitting

Numbers in () are for DS-7014 or DS-8014 Adhesive Kits. All Other Numbers are for DS-7069 or DS-8069 Adhesive Kits

Cont. Size	45° Elbow		90° Elbow		Tee		Coupling		Conc. Reducer		Lateral		Term. Fitting		
	In.	8069	ZC275	8069	ZC275	8069	ZC275	8069	ZC275	8069	ZC275	8069	ZC275	8069	ZC275
3	1			1		1		1				1		1	
4	1			1		1.5		1		1		1.5		1	
6	1.5			1.5		2		1.5		1.5		2		1.5	
8		5		5		6		4		3		6			
10		5		5		7		4		4		7			
12		6		6		8		4		5		8			
14		7		7		10		5		5		10			
16		9		9		11		7		6		12			

Table 5b Quantity of Adhesive Kits Required for Entire Assembly

Numbers in () are for DS-7014 or DS-8014 Adhesive Kits. All Other Numbers are for DS-7069 or DS-8069 Adhesive Kits

Containment Size (In.)	Anchor Assembly ⁽¹⁾	Termination Fitting ⁽¹⁾
3	(1½) 1	(½)
4	(3) 1½	(1)
6	3	(1)
8	(6)	(1½)
10	9	1½
12	9	1¾
14	9	2
16	12	3

(1) The primary joint (coupling) on this fitting is a tapered bell x spigot and **does not** require filler in the adhesive. The secondary containment joint on the straight termination fitting **does** require filler in the adhesive. The secondary containment joint on the tapered termination fitting **does not** require filler.

B. Air Test—Compressed gas (air) tests can be dangerous unless the air test pressure is low. Wear eye protection during inspection of soaped areas. The following low, maximum allowable test pressures (by diameter) make this air test a safe procedure if normal safety precautions are followed:

THESE PROCEDURES MUST BE FOLLOWED IN ORDER TO AVOID SERIOUS PERSONAL INJURY OR PROPERTY DAMAGE. FAILURE TO DO SO WILL RESULT IN LOSS OF WARRANTY, AND BUYER, INSTALLER, OR ANY EMPLOYEE, AGENT, OR REPRESENTATIVE THEREOF, ASSUMES THE RISK OF ANY DAMAGE OR INJURY TO PERSON OR PROPERTY.

Installed NOV Fiber Glass Systems Products pipe systems should be tested prior to use to assure soundness of all joints and connections. In testing, sudden pressure surges must be avoided, as in some instances, surge or hammer can produce pressures of several times the rating of the pipe and fittings.

TESTING WITH AIR OR GAS CAN BE EXTREMELY DANGEROUS. REVIEW SAFETY PRECAUTIONS BEFORE STARTING THE TEST AND FOLLOW ALL TESTING PROCEDURES.

C. Fixtures—Saddles with threaded outlets can be attached to the containment pipe to perform the air test. The installation procedures for containment saddles are the same as for primary saddles in Manual No. F6000. Leave the hose clamps in place.

D. Leakage Checks—Wear eye protection. During the air test, use soap solutions to check the joint for leaks. During the hydro test, watch the gauge pressure and inspect the joint for leaks. Make sure the gauges are accurate.

**•READ THIS CAREFULLY•
SAFETY PRECAUTIONS**

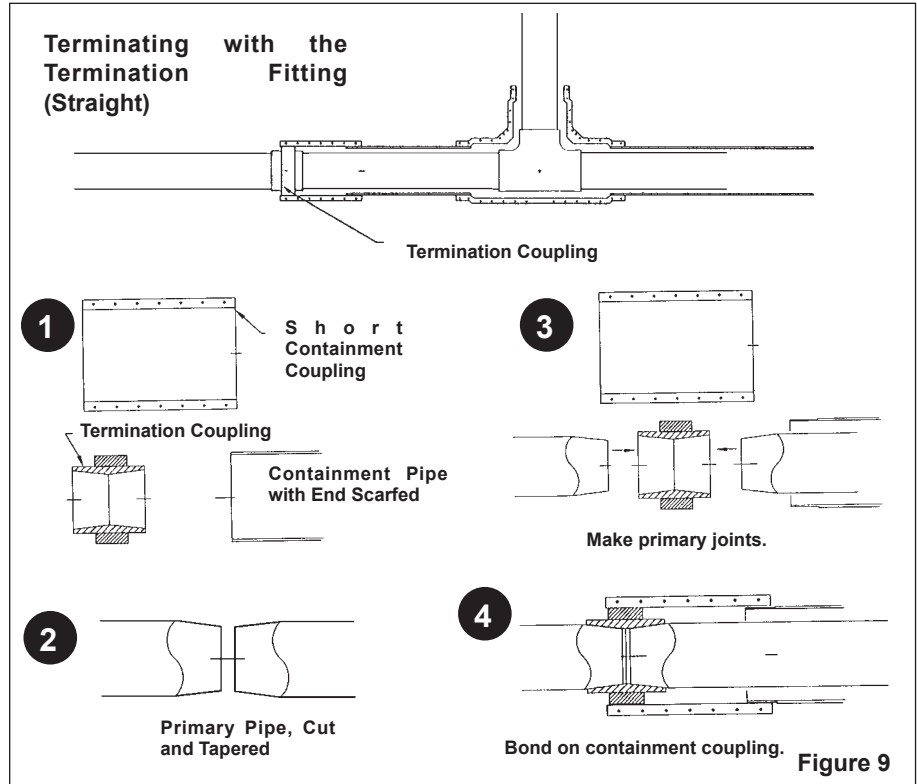

Maximum Allowable Air Test Pressures

Pipe Diameter	3"	4"	6"	8"	10"	12"	14"	16"
psig	15	15	15	14	9	6	5	4

As in any system where pressure is employed, adequate safety precautions should be exercised. EXERCISE DUE CARE IN INSTALLING AND TESTING THE PIPING SYSTEM. DO NOT ASSUME THE RISK OF INJURY OR PROPERTY DAMAGE.

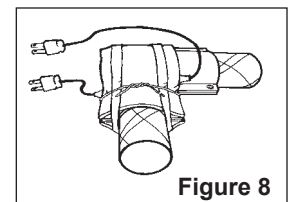

In buried applications, it is suggested that long pipe runs be partially backfilled at various points to secure them in place. All joints and connections should be left exposed for inspection.

In exposed pipe systems, standard pipe guides and hangers will normally be sufficient to restrain the pipe during testing.

Note: The light weight, flexibility, and elasticity of fiberglass pipe create different conditions than are present with steel pipe. **If a failure should occur while testing fiberglass pipe with air or gas, the system will be subject to considerable whipping and other shock-induced conditions due to the sudden release of stored energy. The violent energy release can cause personal injury or death to personnel in the area and can also cause damage to the pipe or other property.**

NOV FIBER GLASS SYSTEMS' PRODUCTS SHALL NOT BE LIABLE UNDER ANY WARRANTY, CONTRACT, OR IN TORT FOR ANY RESULTING INJURY TO PERSONNEL OR DAMAGE TO EQUIPMENT, PIPE, OR OTHER PERSONAL PROPERTY, FOR FAILURE TO FOLLOW THE PROCEDURES AND COMPLY WITH THE PRECAUTIONS SET FORTH.

SECTION 7 Supports, Anchors, & Guides

A. Centralizers, Supports, and Guides—Primary centralizers (and anchors) are required for systems with thermal expansion and/or contraction (see Para. B, Anchors). Spacing of centralizers can be determined from the support spacing information in Manual No. E5000 (Engineering & Design Guide). **DO NOT** put centralizers next to containment fittings. As a general rule, the support spacing must be reduced so the centralizers are located at a maximum distance of three times the primary pipe diameter from the primary fitting (see Fig. 10). **Note: In all cases, centralizers must be at least 6" away from the end of the containment fitting.**

For above-ground installations, with or without centralizers, the support spacing for the containment pipe should be based on the larger (containment) pipe. The design temperature change should be the greater of the two pipes (primary or secondary). Use the support and guide spacing values from Manual No. E5000.

B. Anchors—Containment anchors consist of making a positive connection between the primary and containment pipe, then anchoring the containment pipe to a rigid foundation.

Containment anchors are made up of a special primary pipe coupling and fittings with support risers machined to match the containment pipe scarf diameter. The containment pipe is joined with a special short coupling (see Fig. 11).

a. Installation Procedure—



- 1) Bond the coupling or fitting into the primary pipe line.
- 2) Apply adhesive to all machined areas.
- 3) Use the bottom half of the containment coupling for alignment.
- 4) Use bolts to assemble the top half of the containment coupling.

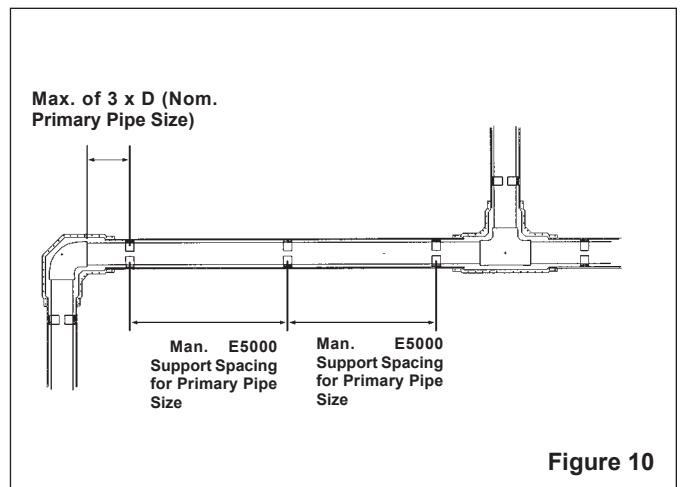

Figure 10

b. Anchor Locations—

Anchors are required for systems with a temperature change that would create length changes in the system. Systems with minimum changes at ambient temperatures do not require anchors.

Systems designed for elevated temperature services must be anchored. All directional and elevational changes must be anchored. Additional anchor locations include straight runs greater than 300 ft., pipe size changes, and connections to other material (refer to Manual No. E5000. Guides must be installed with spacing as shown in Manual No. E5000.

Summary: Anchor the primary pipe to the containment pipe. Use the larger temperature change (primary or secondary) to determine the design conditions. Control the expansion or contraction of the containment pipe using one of the methods in Manual No. E5000.

Note: As shown in Manual No. E5000, non-contained (single pipe) systems that are buried do not require anchors. However, containment (double wall) systems that are buried and have expansion of the primary system do require anchors. When centralizers are used in the system, there is a very small gap between the centralizer and the outer containment pipe wall. When the difference in thermal expansion of the containment pipe and the primary pipe produces movement greater than the values in Table 6, anchors are required. Expansion for both pipe systems can be obtained from Manual No. E5000.

SECTION 8 Repairs

Contact NOV Fiber Glass Systems for recommendations for leaking fittings and fittings joints.

A. Repairing Minor Pipe Damage—Follow the procedures in Manual No. F6000 for repairing pipe wall damage.

B. Repairing Extensive Pipe Damage—Containment sleeve couplings have a space in the center between the socket joints. Therefore, adding a sleeve coupling to the system will increase the total length and/or make up for removed sections of pipe. In some cases, more than one sleeve coupling may be required to replace a damaged pipe section. To prepare the scarf nipples for installing sleeve couplings, refer to the following section for replacement of fittings.

D. Repairing Leaking Containment Fittings—Bond leaks may be repaired by overwrapping the fitting with glass cloth and adhesives provided in the DS-8088 epoxy vinyl ester adhesive maintenance kit from NOV Fiber Glass Systems. The overwrap procedures are similar to those for overwrapping a leaking joint as shown in Manual No. F6000. Exceptions to Manual No. F6000 are as follows:

- Overwrap for containment fittings must cover 4" beyond both edges of the fitting, i.e. overwrap starts 4" on one side of the fitting and continues to 4" on the other side.
- Overwrap **must never be made over uneven surfaces** such as the step at bell ends and tabs

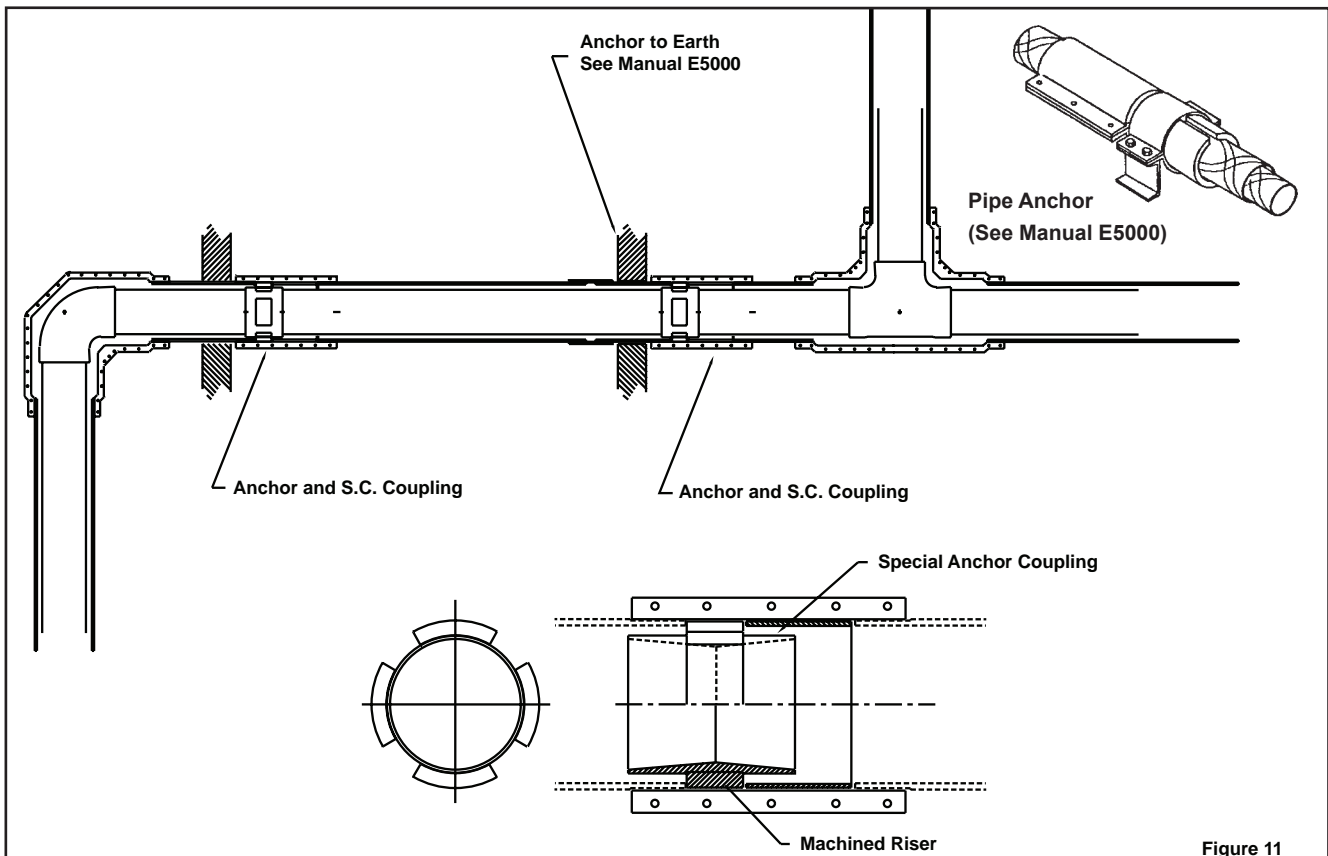

Figure 11

Table 6 Differential Expansion and Contraction Allowance

Containment Size (In.)	Max. Allowable Expansion/Contraction (In.)
3	0.05
4	0.05
6	0.08
8	0.10
10	0.15
12	0.20
14	0.25
16	0.30

(flanges) on the sides of containment fittings. All tabs (flanges) must be cut off, and the sides must be sanded to form a rounded surface. Wrapping over projections will create sharp breaks in the glass pattern. This practice will create voids (weak areas) in the overwrap. For a reliable overwrap, small pen grinders with rounded cutting heads are recommended for bevels at the end of bells and for rounding of tabs.

Refer to Manual No. F6000 for glass application procedures, keeping in mind that the glass cloth must be overlapped from side to side when covering the entire fitting and pipe.

**SECTION 9
Other Considerations**

A. Leak Detection—Several methods of leak detection can be used with the containment system. The type of detection system may dictate the size of the containment pipe and also the types and quantities of fittings for detection wells or pull points. The decision for type of detection should be made early in the design phase, and the manufacturers of leak detection systems should be contacted for the design parameters required for their systems.

The simplest system slopes back to a low point where fluid from a leak will collect. Leaks can then be detected with a sight glass or drain valve for above ground systems. For below ground systems, wells or sumps should be constructed at the low points. Leaks to these wells can be detected visually with removable covers on the wells or electronically with detectors in the well. Several types of detectors are available. The type chosen will dictate the size and type of piping required for installing the detectors. For large systems

and for ease of locating leaks, several detection points may be used.

The most sophisticated system is the continuous monitoring cable systems that can detect leaks within about 12" of the failure. Systems using monitoring cables require clearance for the cable along the bottom of the annulus. A common dimension is a minimum of 3/4" clearance for cable connections. Pipe is typically assembled with pull ropes to pull the cable in after the piping is tested. Electrical fish tapes can be used as an alternate to pull the cable. This requires pull points be designed into the system.

B. Burial—Since two-piece fittings are designed to meet minimum stiffness required by AWWA M45 (American Water Works Association), burial instructions for secondary systems are the same as for primary systems.

C. Static Electricity—Refer to Manual No. E5000, Section 7, Para. E, with consideration that the primary pipe will not be in contact with the ground. When handling non-conductive fluids at high velocities, it may be necessary to ground the primary pipe by wrapping the O.D. (outside diameter) with a conductive material (wire) and installing grounded metal components (such as commercial static eliminators) that make contact with the fluid (liquid) stream. Using threaded saddles to obtain access to the grounding devices in the primary system is practical for this type of application.

D. Water Hammer—Systems with fluid (water) hammer surges significant enough to produce movement in the primary pipe must be anchored to prevent impact against the containment fittings. Refer to Manual No. E5000 for additional information concerning fluid hammer (Section 7, Para. J).

National Oilwell Varco has produced this brochure for general information only, and it is not intended for design purposes. Although every effort has been made to maintain the accuracy and reliability of its contents, National Oilwell Varco in no way assumes responsibility for liability for any loss, damage or injury resulting from the use of information and data herein nor is any warranty expressed or implied. Always cross-reference the bulletin date with the most current version listed at the web site noted in this literature.



www.fgspipe.com

2700 West 65th Street
Little Rock, Arkansas 72209
Phone: 1 (501) 618-2256

25 S. Main Street
Sand Springs, Oklahoma 74063
1 (918) 245-6651

 **Fiber Glass Systems**

©2009, NATIONAL OILWELL VARCO
®Trademark of NATIONAL OILWELL VARCO
F6015 - 2009